

DEFORM™ News

Events:

- May 6 & 7, 2008: The Spring DEFORM User Group Meeting in North America will be held at a location to be announced. Information will be posted on the User Area of the web site as it is finalized. Please mark your calendar.

Training:

- February 5 & 6, 2008: DEFORM-2D training (includes DEFORM-F2) will be conducted at SFTC in Columbus, Ohio.
- February 7 & 8, 2008: DEFORM-3D training (includes DEFORM-F3) will be conducted at the SFTC office.
- April 1 & 2, 2008: DEFORM-2D training (includes DEFORM-F2) will be conducted at SFTC in Columbus, Ohio.
- April 3 & 4, 2008: DEFORM-3D training (includes DEFORM-F3) will be conducted at the SFTC office.
- August 13 & 14, 2008: The annual Die Stress Analysis Workshop will be conducted at Marquette University in Milwaukee, Wisconsin.

Mechanical Joining

In recent years, the three-dimensional (3D) simulation of mechanical joining applications has become practical using DEFORM. Advances in hardware speed and improvements in simulation technology now allow users to simulate 2D or 3D fastening solutions. Users can now model metal forming and mechanical joining within one simulation system.

A wide range of mechanical joining products can benefit from process simulation. Rivets (conventional, clinching, blind), screws (standard, self-piercing, self-threading), nuts, bolts and inserts are just some examples. Processes that 'join by forming' are especially well suited for modeling, since their foundation is based on metal forming principles.

Engineers can realize the same benefits from mechanical joining simulation as they do from metal forming simulation. Simulation can be utilized to optimize processes, test lower-cost designs and reduce development time. Process modeling provides the ability to predict forming defects, tool failures, joint strengths and installation loads.

The following examples illustrate the capability of DEFORM-3D to simulate complex mechanical joining processes.

Mechanically joined systems often include more than one body

undergoing deformation. The Avdel UK Limited Monobolt® simulation, shown below, utilized the discrete multiple deforming body capability of DEFORM. Displacement, stresses and strains in all of the deformable objects were predicted. Engineers at the company were able to develop advanced designs by focusing on an entire fastening system, not just one component.

Modeling of multiple deforming bodies is not feasible without a sophisticated contact algorithm. Independent, arbitrary contact between object pairs is automatically updated at each time step. This capability eliminates the need to predetermine contact locations, as is needed in some general purpose analysis systems. The helical contact shown in the following bolted joint example was defined with nothing more than a contact pair and a friction coefficient.

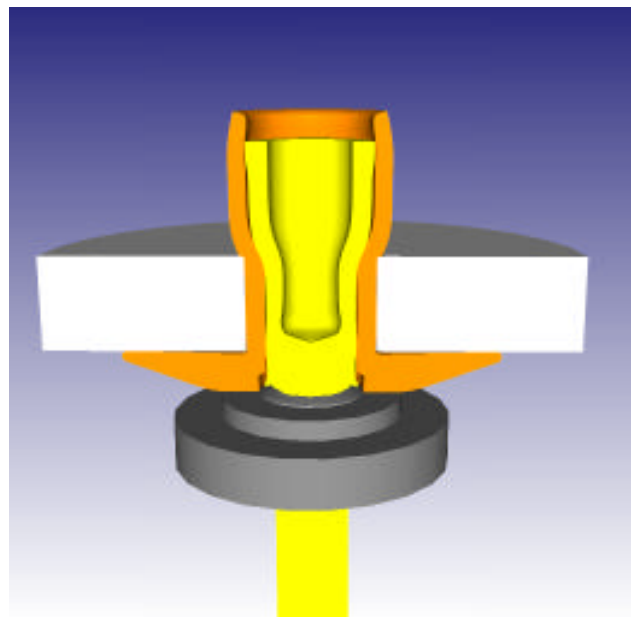

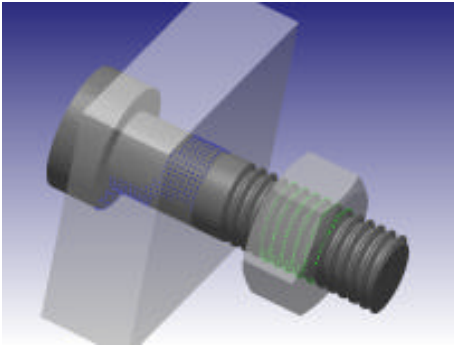

The bolted joint example studied the effect of vibration on preload in a bolted joint system. The graph (top right) shows the bolt loosening and preload reduction that resulted from plate vibration. DEFORM provides a framework for virtual testing by predicting response in complex systems.

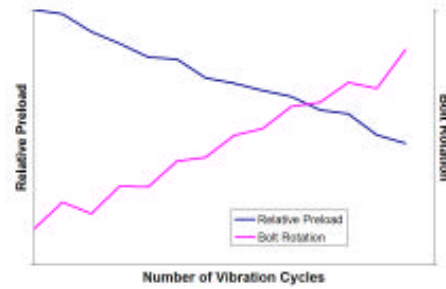

generation capabilities of DEFORM. In this case, a rotating thread drives axial deformation of the part. A fine mesh is necessary on the threads to ensure smoothly evolving contact in this region. Installation was modeled and a region of self-contact was

Complex product assemblies can also be modeled using process simulation. Hercules Industries used 3D simulation to develop an aluminum "breakaway" padlock. Both the lock installation and a required pull test were modeled using DEFORM. Hercules was able to optimize material, heat treatment type and geometry of the lock while predicting joint strength. Simulation results, shown at right, matched prototype tests. The end result was that the manufacturer got to market faster with fewer trials.

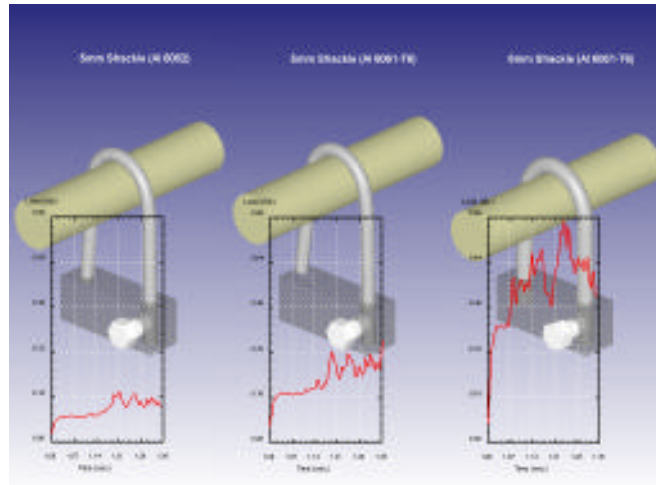

predicted in the folded-bulb area of the fastener. Mesh window, localized remeshing and automatic, adaptive mesh sizing capabilities are all available in DEFORM-3D.

The blind rivet nut example, shown below, highlights the advanced mesh

Contact SFTC today to learn how you can use DEFORM to model your mechanical joining applications.

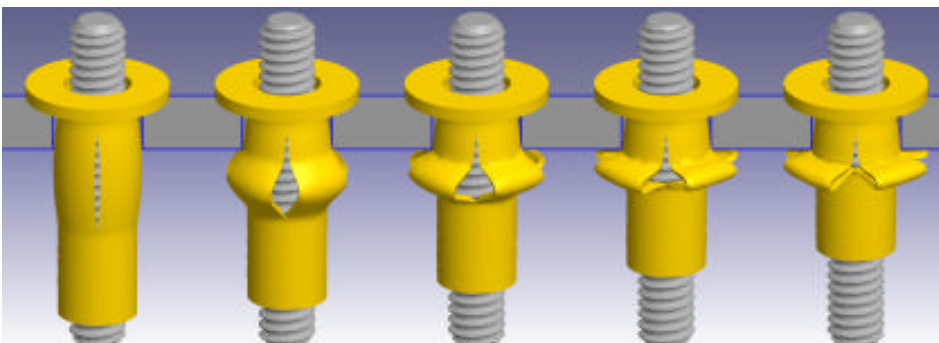

Releases:

DEFORM-2D V9.1 and DEFORM-F2 V9.1 were released on December 26, 2007.

Major features released in 9.1 include:

- new microstructure module that is based on classical JMAK and Cellular Automata models,
- improvements to both the pre and post-processors,
- improvements to the simulation engine.

The following Linux systems are now supported:

- Centos 4.5 (kernel 2.6.9-67)
- Redhat 7.2 (kernel 2.4.20-28.7)
- SuSE 9.2

For a complete list of all the improvements, please refer to the release notes in the DEFORM User Area.

**Scientific
Forming
Technologies
Corporation**



5038 Reed Road
Columbus, Ohio
43220-2514
Tel: (614) 451-8330
Fax: (614) 451-8325

www.deform.com

email: sales@deform.com